

ZWK4-H mit geteilter Klemmnabe - Metallbalg Ausführung with split clamping hub - metal bellow version

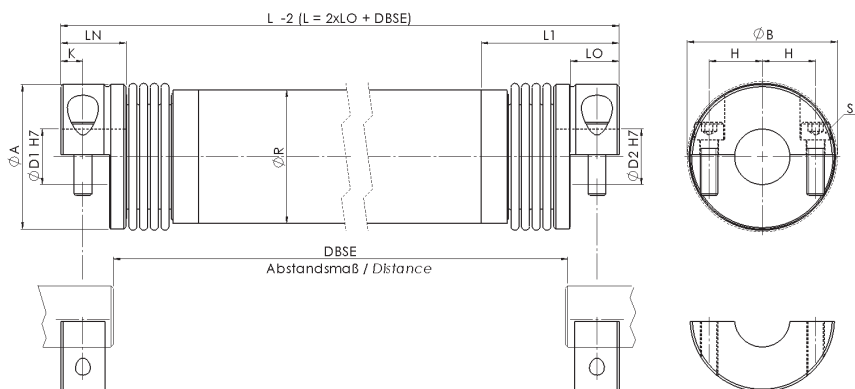

Material:
Balg - Edelstahl
Nabe - Aluminium
Zwischenrohr - Aluminium
Temperaturbereich:
-30 °C bis +120 °C
Optional Passfedernut ØD1 / ØD2:
Nach DIN 6885

Material:
Bellow - stainless steel
Hub - aluminium
Intermediate tube - aluminium
Temperature range:
-30 °C to +120 °C
Optional keyway ØD1 / ØD2:
Acc. to DIN 6885

ZWK4-H		Abmessungen Dimensions										ISO 4762	Technische Daten Technical Data	
Größe Size	TKN	L	ØA	ØD1 / ØD2	LN	LO	L1	ØR	ØB	K	H	S	TA	CT
	[Nm]	[mm]											[Nm]	[Nm/rad]
10	10	82 - 3000	40	6 - 25	14	8,8	42	35	41,5	4,7	15,5	M4	5	3521
18	22	132 - 3000	45	8 - 25,4	20,5	13,5	55	40	47	5,75	17,5	M5	11	4006
30	36	130 - 3000	54	10 - 30	24,5	17	52	50	56	7,5	20	M6	19	9781
60	75	165 - 3000	65	12 - 35	29	22	61	60	67	10	24	M8	42	22600
150	180	196 - 3000	79	14 - 42	34	24	70,5	75	84	11,75	28	M10	83	47169
200	240	218 - 3000	90	20 - 45	38	28	74	90	93	12,5	31,5	M12	145	75797
300	360	220 - 3000	109	24 - 60	38	28	82	100	109	13	39	M12	145	160700
500	600	250 - 3000	119	35 - 62	41,5	31,5	84,5	100	119	14,25	42	M14	255	240740

Weitere technische Daten, siehe Seite 44. Further technical data, see page 44.
Laufend aktualisierte Daten finden Sie auf unserer Homepage. For continuously updated data please refer to our website.

Technische Daten

TKN - Drehmoment
TA - Anzugs-Drehmoment der Schraube
CT - Federsteifigkeit

Technical Data

TKN - Torque
TA - Installation torque per screw
CT - Torsional stiffness

Bestellbeispiel / order example	ZWK4-H	30	800	15	20	SX
Modell / model						
Größe / size						
Länge / length						
Bohrung ØD1 H7 / bore ØD1 H7						
Bohrung ØD2 H7 / bore ØD2 H7						
Sonderoption / special option						

